

XPSMCMCP0802

Controller with 8 inputs 2 outputs monitors expansion modules with screw term



Product availability: Stock - Normally stocked in distribution facility

Price*: 576.00 USD



Main

Range of product	Modicon Safety automation
Product or component type	Safety controller CPU
Device short name	XPSMCM
Electrical connection	Screw terminal
[Us] rated supply voltage	24 V - 20...20 % DC
Number of inputs	8 digital input connection 2 digital interlock start/restart or external device monitoring
Number of outputs	2 safety outputs OSSD contactor/drive connection 4 test line control outputs 2 configurable diagnostic connection
Discrete input voltage	24 V
Discrete output current	400 mA
Discrete input current	400 MA
Discrete input type	Safety input PNP
Discrete output type	PNP
Function of module	Emergency stop conforming to EN/ISO 13850 Guard monitoring conforming to EN/ISO 14119 Enabling switch monitoring conforming to EN/IEC 60947-5-1 Light curtain monitoring conforming to EN/IEC 61496-1 Foot switch monitoring conforming to EN/IEC 60947-5-1 Magnetic switch monitoring conforming to EN/ISO 14119 Two-hand control conforming to EN 574 Safety mat monitoring conforming to EN/ISO 14119 Enabling switch monitoring conforming to EN 61326-1 Muting function of light curtains conforming to EN/IEC 60947-5-1 Counter functions conforming to EN/IEC 61800-5-2 Speed monitoring conforming to EN/IEC 61800-5-2

The information provided in this documentation contains general descriptions and/or technical characteristics of the performance of the products contained herein. This documentation is not intended as a substitute for and is not to be used for determining suitability or reliability of these products for specific user applications. It is the duty of any such user or integrator to perform the appropriate and complete risk analysis, evaluation and testing of the products with respect to the relevant specific application or use thereof. Neither Schneider Electric Industries SAS nor any of its affiliates or subsidiaries shall be responsible or liable for misuse of the information contained herein. *Prices are indicative

Complementary

Synchronisation time between inputs	< 0.5 ms
Power dissipation in W	3 W
Maximum number of I/O expansion module	14 128 input 14 16 output
Integrated connection type	Backplane expansion bus USB 2.0 port
Data storage equipment	SD card (optional)
Inductive load	30 MH
Load capacitance	0.82 MF
Safety level	Can reach category 4 conforming to EN/ISO 13849-1 Can reach PL = e conforming to EN/ISO 13849-1 Type 4 conforming to EN/IEC 61496-1 SILCL 3 IEC 62061
Quality labels	CE
Local signalling	1 LED green with PWR marking for power ON 1 LED green with RUN marking for RUN (status) 1 LED red with E IN marking for internal error 1 LED red E EX external error 1 LED orange with COM marking for communication 1 LED blue with EN marking for master enable 8 LEDs yellow with IN marking for input status 2 LEDs green/red OUT output status 2 LEDs yellow with RST marking for restart signal 2 LEDs yellow with STATUS marking for output channel
Connections - terminals	2 captive screw terminals, removable terminal block 1 captive screw terminals, removable terminal block
Cable cross section	0.00...0.00 In ² (0.2...1.5 mm ²) - AWG 24...AWG 16 flexible without cable end 0.00...0.00 In ² (0.2...2.5 mm ²) - AWG 24...AWG 14 flexible without cable end 0.00...0.00 In ² (0.25...1 mm ²) - AWG 23...AWG 18 flexible with cable end, without-bezel 0.00...0.00 In ² (0.25...2.5 mm ²) - AWG 23...AWG 14 flexible with cable end, with-bezel 0.00...0.00 In ² (0.25...1.5 mm ²) - AWG 23...AWG 16 flexible with cable end, without-bezel 0.00...0.00 In ² (0.5...1.5 mm ²) - AWG 20...AWG 16 flexible with cable end, with double bezel 0.00...0.00 In ² (0.2...1 mm ²) - AWG 24...AWG 18 solid without cable end 0.00...0.00 In ² (0.2...2.5 mm ²) - AWG 24...AWG 14 solid without cable end
Mounting support	Omega 35 mm DIN rail EN 50022
Depth	4.51 In (114.5 mm)
Height	3.90 In (99 mm)
Width	0.89 In (22.5 mm)
Net Weight	0.55 Lb(US) (0.25 kg)

Environment

Standards	EN/IEC 61508 EN/ISO 13849-1 EN/IEC 61496-1 EN/IEC 61800-5-1 IEC 62061
Product certifications	CULus RCM TÜV
IP degree of protection	IP20
Ambient air temperature for operation	14...131 °F (-10...55 °C)
Ambient air temperature for storage	-4...185 °F (-20...85 °C)
Relative humidity	10...95 %
Pollution degree	2
[Uimp] rated impulse withstand voltage	4 KV EN/IEC 61800-5-1

Safety reliability data	PFHd = 6.06E-9 1/h DC > 99 % MTTFd < 100 years high
Insulation	250 V AC between power supply and housing EN/IEC 61800-5-1
Overvoltage category	II
Electromagnetic compatibility	Electrostatic discharge immunity test 6 kV on contact) EN/IEC 61000-4-2 Electrostatic discharge immunity test 20 kV on air) EN/IEC 61000-4-2 Susceptibility to electromagnetic fields 10 V/m 80...1000 MHz) EN/IEC 61000-4-3 Susceptibility to electromagnetic fields - test level: 30 V/m (1.4 GHz...2 GHz) conforming to EN/IEC 61000-4-3
Vibration resistance	+/-0.35 mm 10...55 Hz)EN/IEC 61496-1
Shock resistance	10 gn 16 ms) 1000 shocks on each axis EN/IEC 61496-1
Service life	20 Year(S)

Ordering and shipping details

Category	22477 - SAFETY MODULES (PREVENTA)
Discount Schedule	SAF2
GTIN	03606480748561
Nbr. of units in pkg.	1
Package weight(Lbs)	8.61 Oz (244 g)
Returnability	Yes
Country of origin	IT

Packing Units

Unit Type of Package 1	PCE
Package 1 Height	1.77 In (4.5 cm)
Package 1 width	4.92 In (12.5 cm)
Package 1 Length	6.50 In (16.5 cm)
Unit Type of Package 2	S03
Number of Units in Package 2	26
Package 2 Weight	15.55 Lb(US) (7.052 kg)
Package 2 Height	11.81 In (30 cm)
Package 2 width	11.81 In (30 cm)
Package 2 Length	15.75 In (40 cm)

Offer Sustainability

Sustainable offer status	Green Premium product
California proposition 65	WARNING: This product can expose you to chemicals including: Lead and lead compounds, which is known to the State of California to cause cancer and birth defects or other reproductive harm. For more information go to www.P65Warnings.ca.gov
REACH Regulation	REACH Declaration
REACH free of SVHC	Yes
EU RoHS Directive	Pro-active compliance (Product out of EU RoHS legal scope) EU RoHS Declaration
Mercury free	Yes
RoHS exemption information	Yes
China RoHS Regulation	China RoHS Declaration
Environmental Disclosure	Product Environmental Profile
Circularity Profile	End Of Life Information
WEEE	The product must be disposed on European Union markets following specific waste collection and never end up in rubbish bins.
PVC free	Yes

Dimensions

Screw Terminal

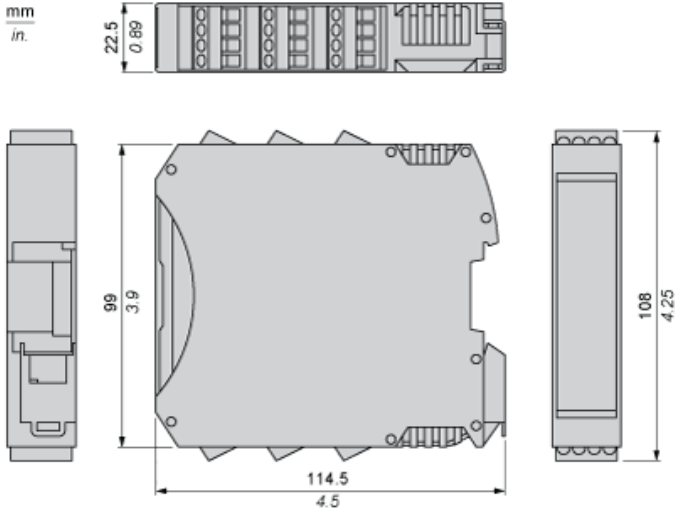

Mounting Safety Controller CPU with Module(s)

Mount BackPlane Connector on Rail

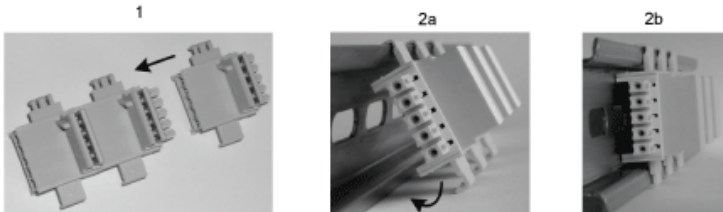

- 1 : Connect as much Backplane Connector as module to be install.
- 2 : Fix the connectors to the rail (Top first).

Mount Safety Controller CPU with Other Module(s)

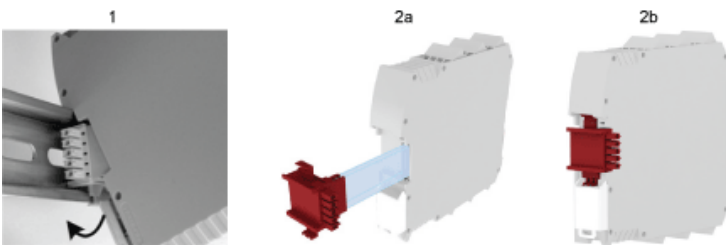

- 1 : Mount controller CPU and modules on rail.
- 2 : Make sure that the controller CPU or the module(s) are plugged on the BackPlane connector.

Wiring

Terminal Designation

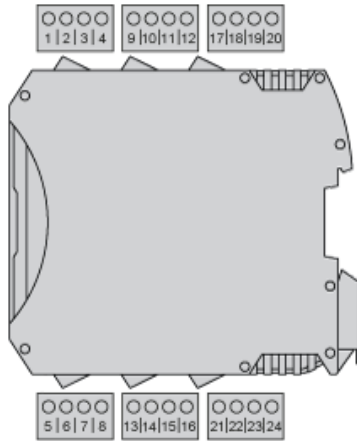

Terminal	Signal	Description
1	24 VDC	24 Vdc power supply
2	MASTER_ENABLE1	Master enable 1
3	MASTER_ENABLE2	Master enable 2
4	0 VDC	0 Vdc power supply
5	OSSD1_A	Static output 1
6	OSSD1_B	
7	RESTART1	Feedback/Restart 1
8	OUT_STATUS 1	Programmable digital output
9	OSSD2_A	Static output 2
10	OSSD2_B	
11	RESTART2	Feedback/Restart 2
12	OUT_STATUS 2	Programmable digital output
13	OUT_TEST1	Short circuit detected output
14	OUT_TEST2	
15	OUT_TEST3	
16	OUT_TEST4	
17	INPUT1	Digital input 1
18	INPUT2	Digital input 2
19	INPUT3	Digital input 3
20	INPUT4	Digital input 4
21	INPUT5	Digital input 5
22	INPUT6	Digital input 6
23	INPUT7	Digital input 7
24	INPUT8	Digital input 8

Wiring Example

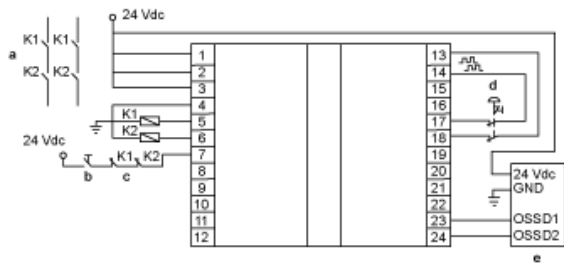

- a : Contactors
- b : Restart
- c : Feedback
- d : Emergency stop
- e : Light curtain

Product Life Status : **Commercialised**